

Customer drawings

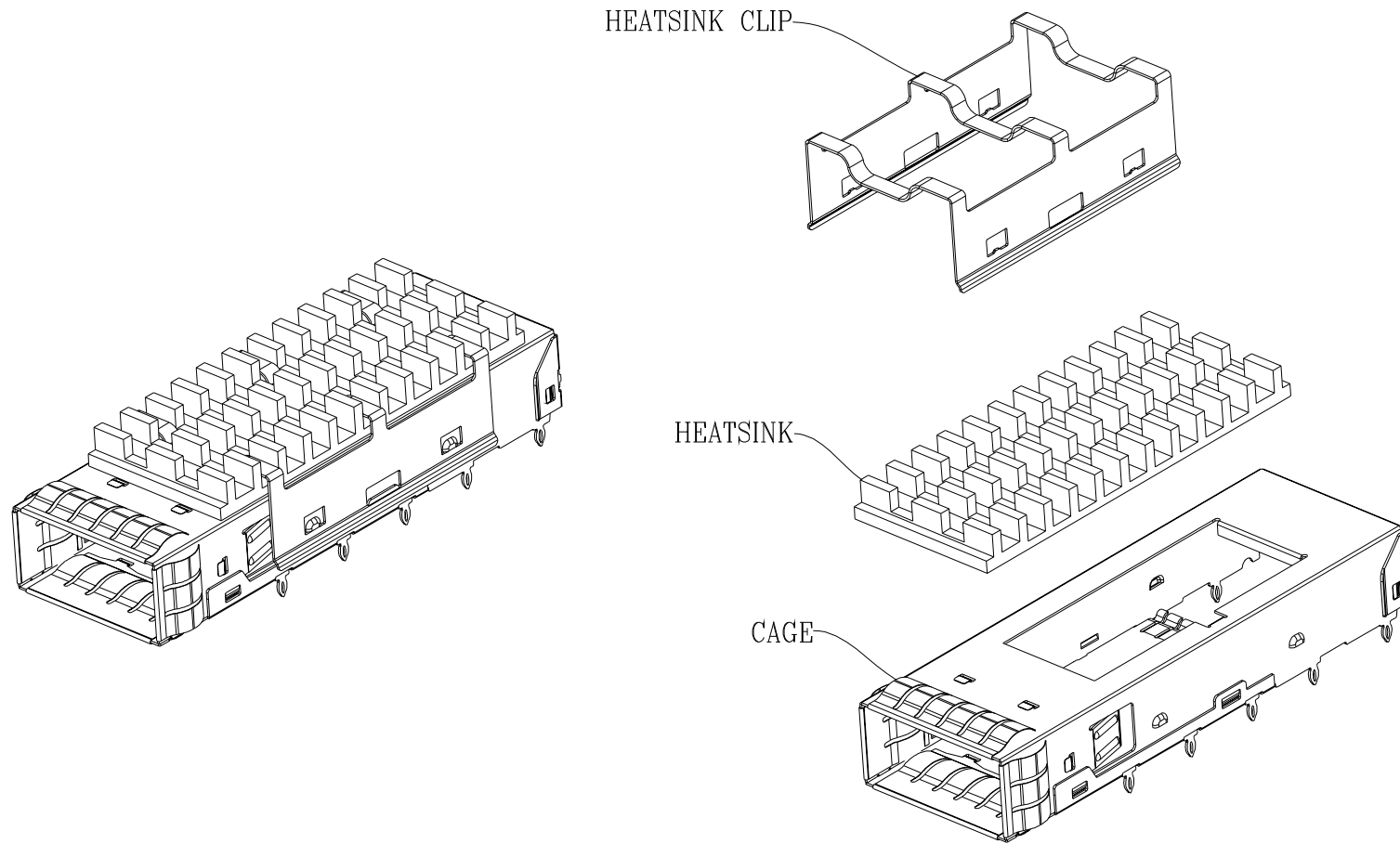

X2	UPDATE DRAWINGS	/	SHMILY
版次	修改说明	ECN 编号	核准

自由公差			
长度尺寸		角度尺寸	
X.	±0.25	X°	±0.5°
.X	±0.25	.X°	±0.5°
.XX	±0.20	.XX°	±0.5°
.XXX	±0.15		
单位	mm	比例	1:1
A4	⊕	页次	1 of 3

设计	Parker	2017.02.23
审核	Linson	2017.02.23
核准	Shmily	2017.02.23

 苏州沃虎电子科技有限公司
SUZHOU WOHU ELECTRONIC TECHNOLOGY CO.,LTD

品名	QSFP+ 1x1 CAGE PRESS-FIT WITH HEATSINK
料号	81-131-00019-1
图号	E8116121101-C
版本	×2

Customer drawings

NOTE:
 MATERIAL:
 1. QSFP CAGE: COPPER ALLOY T=0.25mm.
 2. EMI SPRINGS: COPPER ALLOY T=0.06mm.
 3. HEATSINK CLIP: STAINLESS STEEL T=0.25mm.
 4. HEATSINK: ALUMINUM.
 PLATED:
 1. EMI SPRINGS :PLATING NICKLE 0.76 MICROMETERS MINIMUM FOR ALL.
 2. HEATSINK:PLATING NICKLE 0.76 MICROMETERS MINIMUM FOR ALL.
 ENVIRONMENTAL:
 1. OPERATION: -40°C~+85°C.
 2. STORAGE: -55°C~+105°C.
 3. ROHS COMPLIANT

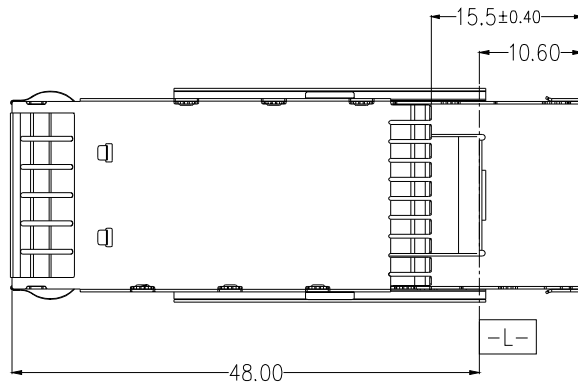
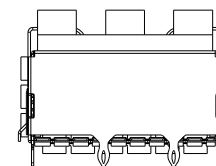
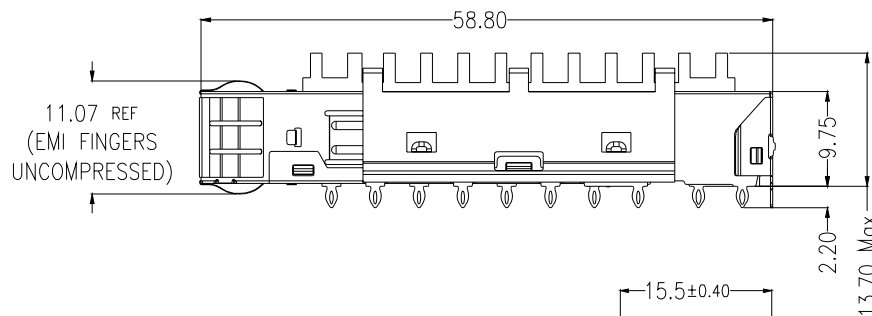
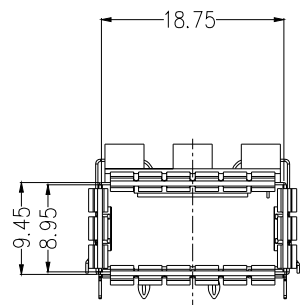
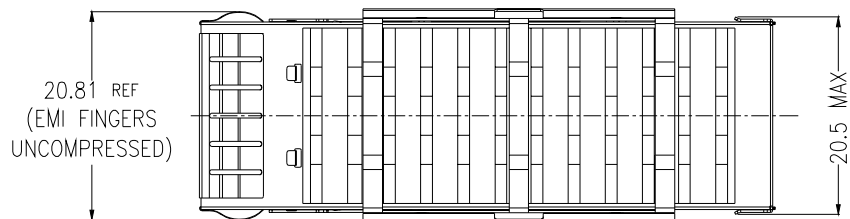

X2	UPDATE DRAWINGS	/	SHMILY	
版次	修改说明	ECN 编号	核准	

自由公差			
长度尺寸	角度尺寸		
X. ±0.25	X' ±0.5°	单位	mm
.X ±0.25	.X' ±0.5°	比例	1:1
.XX ±0.20	.XX' ±0.5°	核	准
.XXX ±0.15		页次	2 of 3

设计	Parker	2017.02.23
审核	Linson	2017.02.23
核准	Shmily	2017.02.23

 苏州沃虎电子科技有限公司
 SUZHOU WOHU ELECTRONIC TECHNOLOGY CO.,LTD

品名	QSFP+ 1x1 CAGE PRESS-FIT WITH HEATSINK
料号	81-131-00019-1
图号	E8116121101-C
版本	X2

Customer drawings

PCB LAYOUT FOR SINGLE SIDED APPLICATION

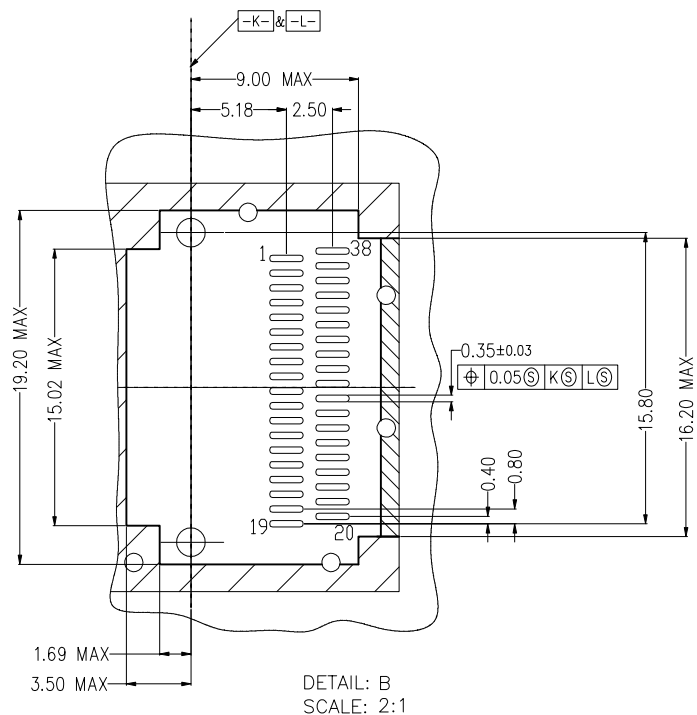
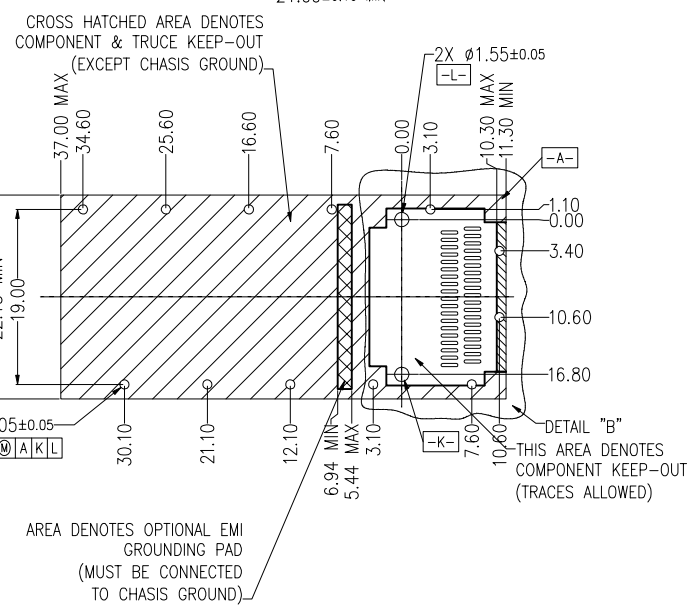
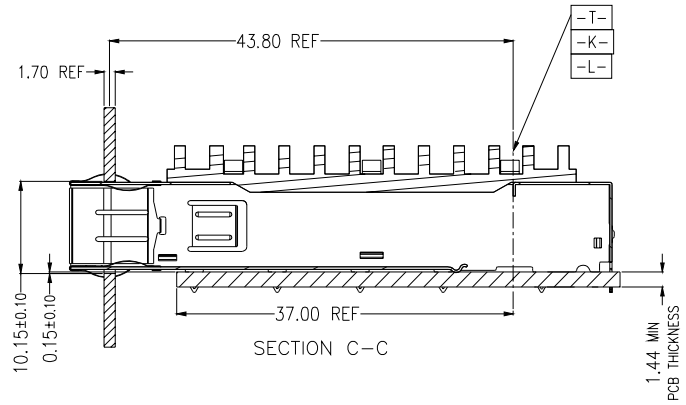
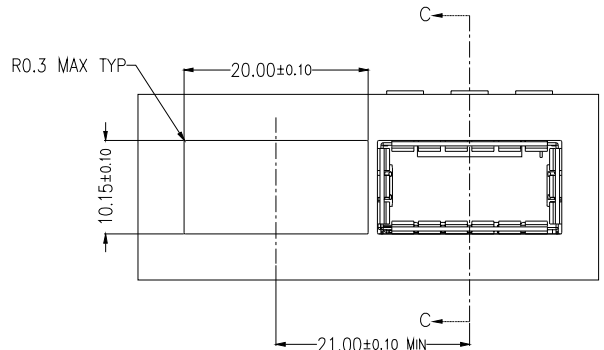

- NOTES:
- SEE QSFP MSA SPECIFICATION FOR BEZEL LOCATION TOLERANCE
 - DATUM -A- IS TIP SURFACE OF HOST BOARD PER MSA
 - FINISHED HOLE SIZE (AFTER PLATING)
 - DATUM -K- IS HOST BOARD THRE HOLE #1 TO ACCEPT CONNECTOR GUIDE POST PER MSA
 - DATUM -L- IS HOST BOARD THRE HOLE #2 TO ACCEPT CONNECTOR GUIDE POST PER MSA
 - DATUM -T- IS HARD STOP ON CAGE PER MSA

X2	UPDATE DRAWINGS	/	SHMILY
版次	修改说明	ECN 编号	核准

自由公差		设计	2017.02.23	苏州沃虎电子科技有限公司 SUZHOU WOHU ELECTRONIC TECHNOLOGY CO.,LTD
长度尺寸	角度尺寸			
X. ±0.25	X' ±0.5°	Parker		品名 QSFP+ 1x1 CAGE PRESS-FIT WITH HEATSINK
.X ±0.25	.X' ±0.5°	审核 Linson	2017.02.23	
.XX ±0.20	.XX' ±0.5°	核准 Shmily	2017.02.23	
.XXX ±0.15				料号 81-131-00019-1
单位 mm	比例 1:1			图号 E8116121101-C
A4	页次 3 of 3			版本 X2