

REV.	DESCRIPTION	NAME	DATE
A	NEWS ISSUE		

NOTE:

- MATERIAL SPECIFICATION:
 - HOUSING: HIGH TEMPERATURE RESISTANT PLASTIC, UL94 V-0.
 - CONTACTS: COPPER ALLOY
 - MID-PLATED: STAINLESS STEEL
- PLATING SPECIFICATION:
 - CONTACTS:
 - Ni 50u" MIN. UNDER PLATED OVER ALL.
 - Au PLATED ON THE FUNCTIONAL AREA OF CONTACT. (GOLD PLATING THICKNESS FOLLOW THE P/N)
 - GOLD FLASH PLATING ON SOLDER AREA
 - FRONT SHELL:
 - Ni 30u" MIN. UNDER PLATED OVER ALL.
- MECHANICAL PERFORMANCE,
 - INSERTION FORCE: 0.5~2.0kgf.
 - REMOVAL FORCE: 0.8kgf~2.0kgf.
 - DURABILITY: 10000 CYCLES.
- ELECTRICAL PERFORMANCE,
 - CURRENT RATING: 5.0A
VOLTAGE RATING: 20V
 - INSULATION RESISTANCE: 100MΩ MIN
 - DIELECTRIC WITHSTAND VOLTAGE, AC 100V FOR TERMINAL.
 - LOW CONTACT RESISTANCE: INITIAL 40MΩ
- ENVIRONMENTAL PERFORMANCE:
 - OPERATING TEMPERATURE: -30°C~+80°C.
- IR REFLOW:
 - THE PEAK TEMPERATURE ON THE BOARD SHALL BE MAINTAINED FOR 10 SECONDS AT 260°C.

USB TYPE-C PIN ASSIGNMENTS

Code	DIM L	DIM A
0	6.80	4.90
1	6.50	4.60

PIN NUMBER	SIGNAL NAME
A5	CC1
A9	VBUS
A12	GND
B12	GND
B9	VBUS
B5	CC2

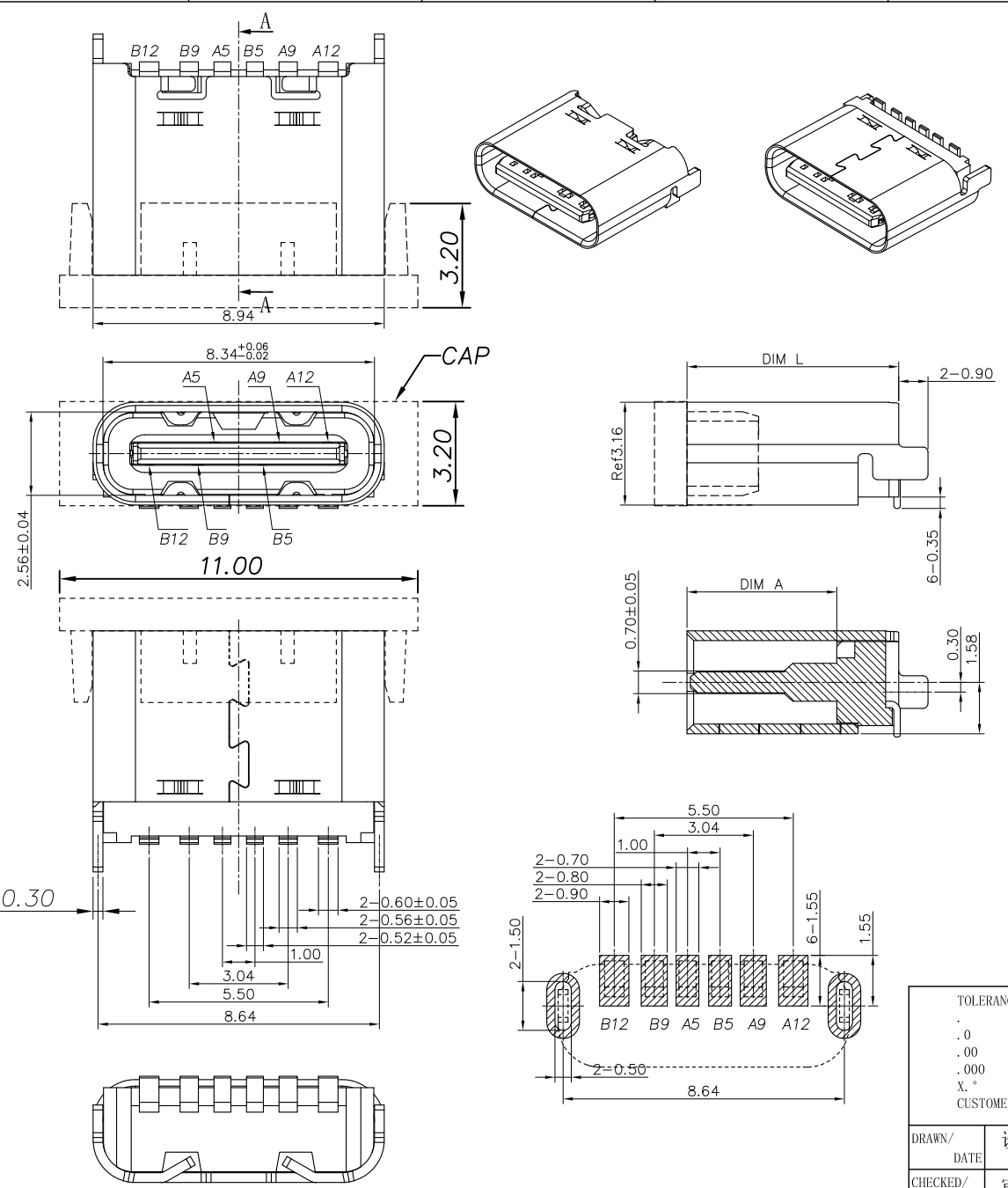

RECOMMEND P.C.B LAYOUT (COMPONENT SIDE)
TOLERANCE FOR PCB LAYOUT IS ± 0.05

TOLERANCE UNSPECIFIED		苏州沃虎电子科技有限公司 Tel: 4001048018 http://www.wohu-tek.com	
.0	±0.35		
.00	±0.25	TITLE: TYPE-C 6P母座直立式贴片H=6.5 带中夹片	
.000	±0.15	DRAWN/ DATE: 设计 LYX	SIZE: A4 UNIT: MM. PART. NO: UC.01.63-11-0005
X. °	±2.00°	CHECKED/ DATE: 审核 HMY	SCALE: 1:1 PROJECTION:
CUSTOMER DRAWING		APPROVED/ DATE: 核准 LJP	DWG. PATH: 0100-2
		REV.: 版本	
		SHEET: 页码	

REV.	DESCRIPTION	NAME	DATE
A	NEWS ISSUE		

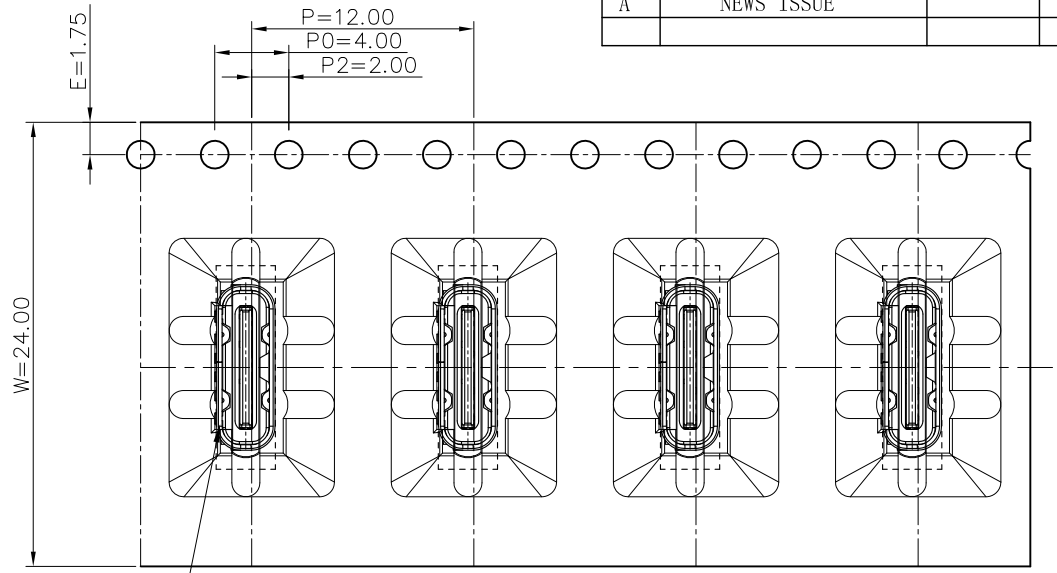
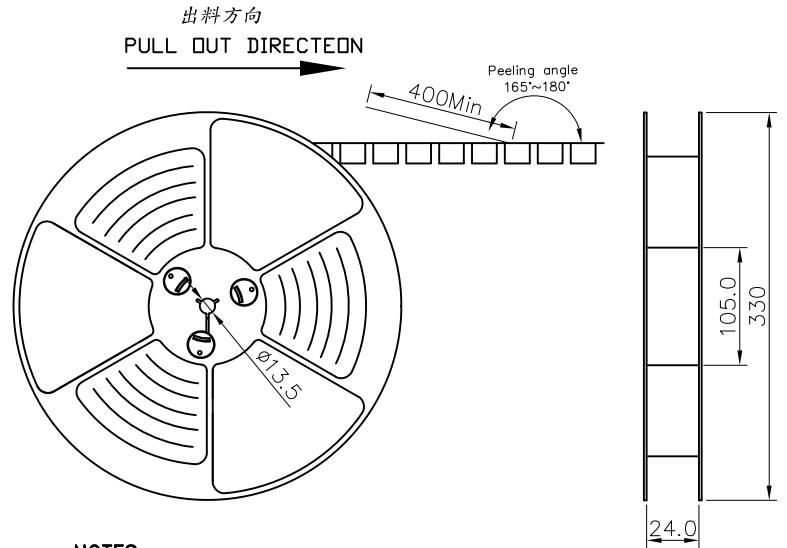

NOTES

1. 帶子引導長度
LEAD TAPE LENGTH
出料方向
PULL OUT DIRECTEON

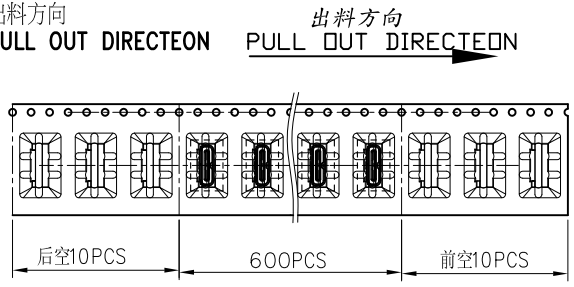

2. 上帶 剝力力為：0.1~1.3N(10.2gf~130gf)
PEELING OFF FORCE OF TOP TAPE:0.1~1.3N(10.2gf~130gf)
出貨運輸過程中一定注意：
THIS REQUIREMENT SHOULD BE APPLIED AT SHIPMENT：
卷帶在運輸過程中不能散開
PEELING OFF SHOULD NOT BE ALLOWED DURING TRANSPORTATION

焊脚插左

TAPE & REEL 10 PCS

BOX

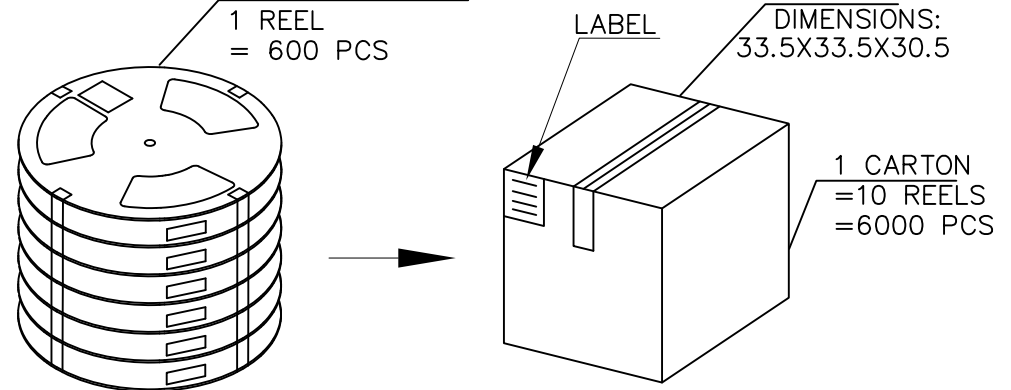

包裝明細表 (The detail of the packing)						
產品料號 (Product No.)	包裝容量 (Packing Capacity)			重量 Weight (Kg)		
	pcs/box	boxs/Carton	Pcs/Box	N.W./Pcs	N.W./Box	G.W./Box
	600	10	6000	----	----	----

TOLERANCE UNSPECIFIED		苏州沃虎电子科技有限公司 Tel:4001048018 http://www.wohu-tek.com		TITLE:	
.0	±0.35			TYPE-C 6P母座直立式贴片H=6.5 带中夹片	
.00	±0.25	DRAWN/ DATE	设计 LYX	SIZE:A4	UNIT:MM.
.000	±0.15	CHECKED/ DATE	审核 HMY	PART. NO:	UC.01.63-11-0005
X.°	±2.00°	APPROVED/ DATE	核准 LJP	SCALE: 1:1	PROJECTION
CUSTOMER DRAWING		DWG. PATH		0100-2	
				REV.: 版本	
				SHEET: 页码	