

REACH & RoHS
COMPLIANT

SUGGESTED PANEL OPENING:

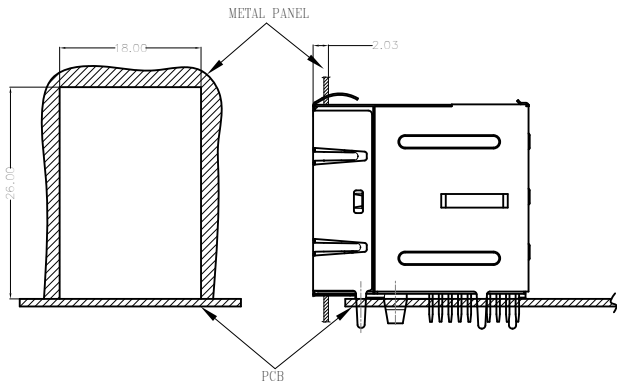

UNIT: MM / INCH
TOLERANCES: $\pm 0.10 / 0.004$

KEEP-OUT AREA (COMPONENT SIDE VIEW):

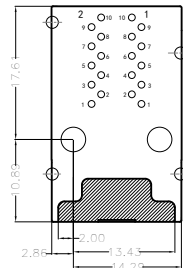

PLUG-IN SIDE

UNIT: MM / INCH
TOLERANCES: $\pm 0.10 / 0.004$

VOOHU

苏州沃虎电子科技有限公司
Su Zhou VooHu ElectronicTech.Co.Ltd

TEL: +86 400 1048 018

WEB: www.vohu-tek.com

TITLE:
RJ45 2X1 1000BASE

PART NO.:
SYT21Q042HWA4D068

REMARK:

SIZE
A4

SACLE
1:1

SHEET
2/4

UNITS
MM[INCH]

REV
A2



GENERAL TOLERANCES
UNLESS SPECIFIED

$x \pm 0.35$	$x^\circ \pm 3.0^\circ$
$.xx \pm 0.30$	$.x^\circ \pm 2.0^\circ$
$.xxx \pm 0.25$	$.xx^\circ \pm 1.5^\circ$
$.xxx \pm 0.10$	$.xxx^\circ \pm 1.0^\circ$

APPROVED BY:
Geoffrey.Song

CHECKED BY:
Elvis.Song

DESIGN BY:
Sunny.Xu

REACH & RoHS
COMPLIANT

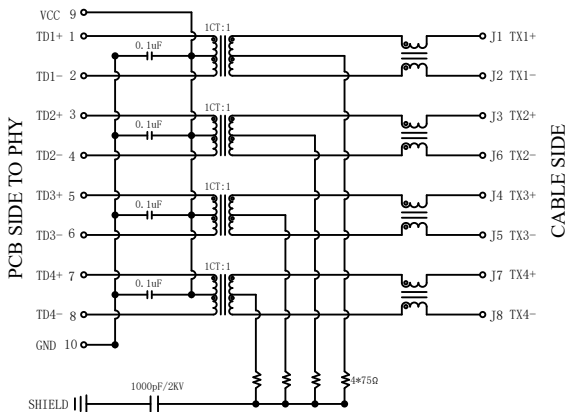

Electrical:

- Turn ratio: 1~2: J1~J2 = 1CT:1CT(±2%) .
3~4: J3~J6 = 1CT:1CT(±2%) .
5~6: J4~J5 = 1CT:1CT(±2%) .
7~8: J7~J8 = 1CT:1CT(±2%) .
- OCL: 350uH Min.at 100KHz 100mV 8mA DC.
- Insertion Loss: -1.0 dB Max 1 ~100MHz.
- Return loss: -18dB Min 1 ~30MHz;
-1 4dB Min 30~60MHz.
-1 2dB Min 60~80MHz.
-10dB Min 80~100MHz.
- Cross talk: -40dB Min 1 ~30MHz;
-35dB Min 30 ~60MHz;
-30dB Min 60 ~100MHz;
- CMR: -3 0dB Min 1 ~100MHz;
- Hi-Pot: 2250V DC 6S 1mA PRI TO SEC



苏州沃虎电子科技有限公司
Su Zhou VooHu ElectronicTech.Co.Ltd

TEL: +86 400 1048 018

WEB: www.vohu-tek.com

TITLE:
RJ45 2X1 1000BASE

SIZE
A4
UNITS
MM[INCH]

GENERAL TOLERANCES
UNLESS SPECIFIED

APPROVED BY:
Geoffrey.Song

PART NO.:
SYT21Q042HWA4D068

SACLE
1:1
REV
A2

x±0.35	x°±3.0°
.xx±0.30	.x°±2.0°

CHECKED BY:
Elvis.Song

REMARK:

SHEET
3/4

.xx±0.25	.xx°±1.5°
.xxx±0.10	.xxx°±1.0°

DESIGND BY:
Sunny.Xu

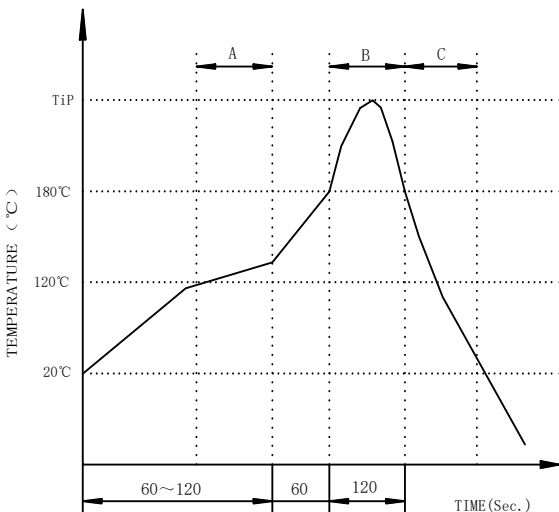

REACH & RoHS
COMPLIANT

PROFILE OF WAVE SOLDER



A.Preheating B.Soldering C.Gradual Cooling
 Tip temperature:260±5°C.
 Tip temperature time:5Sec Max.
 Tip melting point of Sn96.5/Ag3/Cu0.5:217°C.

Remarks: after wave soldering, the plastic positioning columns of the product which under the PCB will be slightly melted, but it won't affect its function.

 苏州沃虎电子科技有限公司 Su Zhou VooHu ElectronicTech.Co.Ltd	TITLE: RJ45 2X1 1000BASE	SIZE A4	UNITS MM[INCH]	GENERAL TOLERANCES UNLESS SPECIFIED		APPROVED BY: Geoffrey.Song
	PART NO.: SYT21Q042HWA4D068	SACLE 1:1	REV A2	x±0.35	x°±3.0°	CHECKED BY: Elvis.Song
TEL: +86 400 1048 018 WEB:www.vohu-tek.com	REMARK:	SHEET 4/4		.xx±0.25	.xx°±1.5°	DESIGN BY: Sunny.Xu
				.xxx±0.10	.xxx°±1.0°	